



LIBELLULA 1-3''

SELF-PRIMING DIAPHRAGM PUMP

USE AND MAINTENANCE INSTRUCTIONS



Read this user manual before installing, starting, using or carrying out technical work on this equipment.

Compliance with the use and maintenance instructions in this manual will preserve the efficiency and reliability of the unit over time.

INSTRUCTIONS TRANSLATED FROM ORIGINAL LANGUAGE



WARNING!

DO NOT OPERATE THE PUMP BEFORE HAVING READ AND UNDERSTOOD THIS MANUAL.

CAFFINI CIPRIANO SRL DECLINES ANY AND ALL LIABILITY FOR DAMAGE DUE TO NEGLIGENCE AND FAILURE TO COMPLY WITH THE INSTRUCTIONS IN THIS MANUAL.

CAFFINI CIPRIANO SRL SHALL NOT BE LIABLE FOR DAMAGE CAUSED BY MISINTERPRETATION OF THE INSTRUCTIONS OR FOR DAMAGE CAUSED BY INCORRECT INSTALLATION AND/OR IMPROPER USE OF THE PUMP.

CONTENTS

1. INTRODUCTION	5
2. WARRANTY.....	5
3. MANUFACTURER	5
4. INFORMATION ON THE NAMEPLATES	6
5. MACHINE DESCRIPTION.....	7
6. USE AND APPLICATION	8
7. SOUND LEVEL	8
8. SAFETY AND ACCIDENT PREVENTION	9
9. SAFETY RULES	10
10. HANDLING AND TRANSPORT.....	12
11. STORAGE.....	13
12. INSTALLATION.....	14
13. BEFORE START-UP	16
14. MAINTENANCE.....	17
15. SPARE PARTS	19
16. MALFUNCTIONS, CAUSES AND REMEDIES.....	21
17. SPECIFICATIONS.....	22
18. DISPOSAL	23

1. INTRODUCTION

This manual contains the information and everything deemed necessary for understanding, proper use and routine maintenance of the Libellula 1-3" pump (hereinafter also referred to as the machine), manufactured by CAFFINI CIPRIANO S.r.l., hereinafter also referred to as the Manufacturing Company or Manufacturer. Failure to comply with the instructions in this manual will cause the warranty provided by the Manufacturing Company for the machine to be void. For any repairs or overhauls involving operations of a certain complexity, contact the Manufacturing Company directly. The Manufacturer remains fully available to provide prompt and accurate technical assistance.

These instructions are to be considered translated from the original language.

2. WARRANTY

Upon receipt, immediately check the condition of the material, especially any damage caused during transport. Also check exact correspondence with the transport document. Any claims must, under penalty of forfeiture, be immediately raised with the carrier on the transport document and notified to the Manufacturer within seven days by registered letter with return receipt. For any communication, always indicate the machine type and model printed on the relevant nameplate or stamped near the oil filler cap, and the serial number and/or series number. All our products are guaranteed for 12 months from the delivery date. Repairs carried out under warranty do not interrupt the warranty period. The warranty covers material and workmanship defects that compromise product operation and make it unsuitable for its intended use, provided they are reported promptly and in any case within 2 days of their discovery. Damage resulting from the physical/chemical characteristics of the liquid drawn in is excluded, as is damage to parts which by their nature or purpose are subject to wear or deterioration (seals, diaphragms, suction and delivery valves, rubber or plastic parts), or that depends on failure to follow our use or maintenance instructions, improper or inadequate use or storage of the product, or modifications or repairs carried out by personnel not expressly authorised by us. For further details, please refer to *Caffini General Warranty Terms and Conditions*.

3. MANUFACTURER

The pumps in the Libellula 1-3" series are manufactured by CAFFINI CIPRIANO S.r.l., headquartered in Lemignano di Collecchio (Parma) - ITALY - Postcode 43044 - Via G. Di Vittorio no. 46 - Tel. +39 0521 804325 Fax +39 0521 804145 - e-mail: info@caffinipumps.it; certified e-mail: caffinipec@legalmail.it - REA no. PR-202507 - Parma Companies Register - tax code and VAT no. IT02002550347.

4. INFORMATION ON THE NAMEPLATES

Each pump is fitted with a nameplate providing information about the pump. The nameplates are located on the gearbox support or on the guard, and show:

- Model
- Serial number
- Weight
- Maximum engine/motor speed
- Engine/motor power
- Maximum flow rate
- Maximum pressure



The serial number uniquely identifies the pump and is essential for the correct supply of any spare parts. The serial number is also stamped on the side of the gearbox.



IMPORTANT!

If worn, the nameplates must be re-applied.

5. MACHINE DESCRIPTION

The Libellula 1-3" is a self-priming diaphragm pump with 3" GAS BSPP threaded suction and delivery ports (aluminium version only) or DN80 PN10 flanged ports. The diaphragm is actuated by a self-lubricating flexible or rigid connecting rod that requires no maintenance for up to 5000 working hours.

The gearbox connecting the motor/engine to the connecting rod-crank system may be made of light aluminium alloy or cast iron. The transmission gears may have spur or helical teeth with transmission ratios of 1:43, 1:38 or 1:30, to provide the required flow rate as the drive motor/engine speed varies.

The materials used for the metal parts in contact with the liquid may be: aluminium alloy, cast iron, AISI 316 stainless steel, aluminium alloy plastic-coated with Rilsan, coated with fluorinated thermoplastic polymer compatible with FDA standards. The diaphragm and valves may be made of the following materials: Neoprene, Viton, oil-resistant rubber or TPV thermoplastic material compatible with FDA standards.

The machine is equipped with a fixed PVC guard covering the connecting rod-crank system to prevent injuries due to contact between the operator and moving parts. The fixed guard is locked and held in its correct position by fastening bolts.

The construction-site version of the Libellula 1-3" is made with pump body, suction and delivery ports, gearbox support and connecting rod in die-cast aluminium, while the industrial version is in cast iron

The Libellula 1-3" pump can be driven by different types of motor/engine, such as:

Petrol:

- Honda GX160

Diesel:

- Hatz 1B20-7
- Kohler KD15-350
- Yanmar L48

Electric motors:

- Three-phase 230/400V (or 400/690V), externally self-ventilated, class F insulation, IP55 protection, compliant with IEC or NEMA C standards.
- Three-phase explosion-proof motor compliant with Directive 2014/34/EC (ATEX).
- Single-phase enclosed, externally self-ventilated motor.

Battery-powered:

- Honda EGX2.0H

The pump-motor/engine coupling is a monobloc unit with suitable flange and pinion. For petrol/diesel engines, the coupling flange is SAE 609 A, while for electric motors the standard is frame size 90. Different motor/engine models may be installed subject to technical verification and approval.

The Libellula 1-3" can be installed: on a fixed base, on a portable stretcher frame, on a trolley for electric, petrol or diesel motor/engine with handlebar guide or protective frame.

6. USE AND APPLICATION

6.1 Intended use

The pump is suitable for handling liquids or sludge with suspended solids.

The pump can run dry indefinitely.

The Libellula 1-3" may also be suitable for transferring food liquids; in this case, the user must ensure that the materials in contact with the product comply with the relevant directives.

The machine is designed and built so that the parts in contact with the product to be pumped can be cleaned before each use; all connection elements are smooth, without roughness or spaces where organic material can collect; surfaces in contact with food products can be easily cleaned and disinfected.

6.2 Unintended use

The pump is not suitable for transferring hazardous or flammable liquids, or liquids that may generate a potentially explosive atmosphere, except in the ATEX-certified version. If the pump is used to transfer chemical products that are particularly hazardous in contact with persons or property, the correct choice of metal materials and elastomers for the pump parts that will come into contact with the fluid must be checked with the supplier.

The installer must create, in the pump operating area, a basin suitable for containing any fluid that may leak due to accidental rupture of the pumping diaphragm, and must install remote controls for starting and stopping the machine and drain pipes for the fluid collection basin, so that maintenance operations can be carried out.

7. SOUND LEVEL

During operation, the machine in the aluminium version equipped with a 2800 rpm electric motor has a measured sound power level $L_{wA}=89$ dB(A) and a guaranteed sound power level of 90 dB(A).

In the cast-iron version equipped with a 1400 rpm electric motor, it has a measured sound power level $L_{wA}=77$ dB(A) during operation and a guaranteed sound power level of 78 dB(A).

For the other versions of the Libellula 1-3" pump equipped with petrol or diesel engine, refer to the sound power level of the installed engines indicated on the EC Certificate of Conformity.

The manufacturer remains available to users to provide cumulative distribution curves and time and frequency measurements of the sound pressure level of the Libellula 1-3" pump, should any soundproofing intervention be necessary.

8. SAFETY AND ACCIDENT PREVENTION



IMPORTANT!

The employer is required to provide PPE (Personal Protective Equipment) and inform personnel on its correct use and maintenance.



IMPORTANT!

The operator must always comply with the instructions shown on the signs affixed to the machine.

The PPE that the operator must use during Maintenance and Cleaning operations is:

- work clothing
- gloves
- safety shoes with steel toe cap
- hearing protectors
- mask



9. SAFETY RULES



Do not carry out maintenance operations during operation.



Do not run the petrol or diesel engine inside an enclosed area. Exhaust gases contain carbon monoxide, an odourless and deadly poison.



Do not place hands or feet near moving or rotating parts.



Do not keep, pour or use fuels in the presence of an open flame, or near devices such as stoves, boilers or equipment capable of generating sparks.



Do not refuel in enclosed or poorly ventilated areas.



Do not refuel during operation. Allow the engine to cool before refuelling. Store fuels in suitable containers approved according to safety standards.



Do not remove the fuel tank cap while the engine is running.



Do not run the engine if there is a smell of petrol or any other risk of explosion.



Do not start the engine if fuel has leaked.



Do not transport the engine with petrol in the tank.



Do not check ignition with the spark plugs or spark plug cable disconnected: use a suitable tester.



Do not crank the engine with the spark plug removed.



Do not strike the flywheel with blunt or metal objects, as this may cause metal parts to break and detach during movement.



Do not touch mufflers, cylinders or cooling fins when hot, as contact may cause burns.



To prevent parts from striking people if the machine falls, make sure that no persons are within the operating radius of the lifting equipment during lifting operations.



Lifting, transport and positioning operations must be carried out by qualified technical personnel trained in the specific fields of work.
Before each handling operation, always ensure that the lifting equipment and related accessories (ropes, hooks, etc.) are suitable for lifting the load to be handled, and check the required stability of the load.

Do not use the PUMP in ways other than those intended by the manufacturer and indicated in the Use and Maintenance instructions.

Also pay particular attention to:



Danger: suspended loads



Do not stand under loads



Do not remove safety devices



Do not repair and/or lubricate moving parts

10. HANDLING AND TRANSPORT

The machine may only be handled with the suction and delivery pipes disconnected and with the power unit stopped or disconnected.

Machines installed on a base can be handled using lifting equipment that can be connected, with suitable safety systems, to the lifting hook provided on the machine. To lift the machine on a stretcher frame/protective trolley, use the central part of the upper (removable) crossbar as the lifting point, ensuring that this is done as shown in the image below.



Before any handling operation of pumps on a stretcher frame/protective trolley, check that the four fastening screws of the (removable) crossbar are properly tightened.

INCORRECT!

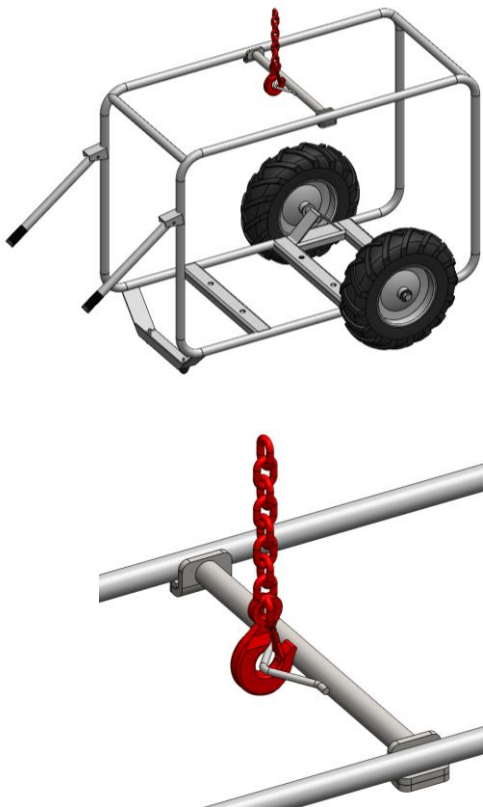

CORRECT

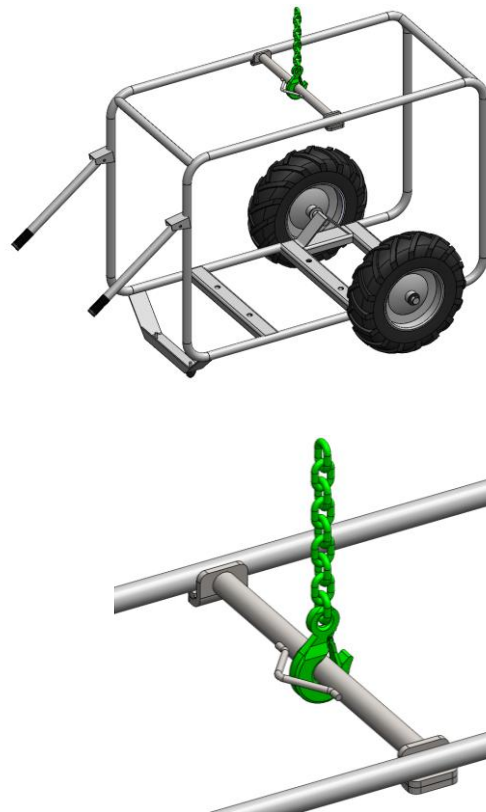

The machine must be transported in a horizontal position and under optimal safety conditions.

Pay also attention to:

- Lift the unit using only the designated lifting points.
- Before handling the machine, check its dimensions and weights from the nameplate.
- Do not stand within the operating radius while the machine is being handled.
- During installation and maintenance work, safe transport of all components must be ensured using suitable slings. Handling must be carried out by specialised personnel to avoid damaging the machine and causing injury to personnel.
- The lifting points of the various components must be used only to lift the components for which they were provided.
- Do not stand or pass under or near the machine when it is raised from the ground.
- To secure the machine to the transport platform, fasten it with ropes or chains.



No additional accessory may be connected to the motor pump or electric pump unit during lifting or handling.

11. STORAGE

For storage, place the machine in an enclosed area; if left outdoors, cover it with a waterproof sheet. Avoid accumulation of moisture around the machine. Do not leave the pump body full of liquid. Empty it through the drain plug provided. In winter months, the liquid could freeze and damage the system. When the liquid is hazardous, before emptying the tank, take all precautions to prevent damage and injury. Periodically start the pump for a few seconds to prevent deposits inside the pump.

12. INSTALLATION

For use of the motors/engines coupled to the pump, express reference is made to the rules issued by the motor/engine manufacturers, attached to this use and maintenance manual.

Install electric pump or motor pump units with metal base on stable foundations firmly anchored to the ground. The pipes connected to the pump must be flexible or, where possible, fitted with flexible rubber sections to dampen vibrations due to pulsating flow.

It is good practice to prevent large solid bodies (maximum size 50 mm), which could cause the diaphragm or connecting rod to break, from entering by fitting a protective suction filter, available on request.

The suction and delivery lines must have a diameter equal to or greater than that of the pump suction or delivery ports. Avoid bends, elbows or restrictions as much as possible, as they may limit the inflow or outflow of liquid to or from the pump.

Do not fit foot valves: the pump is equipped with flap valves that act as non-return valves.

Do not fit flow-throttling valves on the delivery line; to reduce the flow rate, provide a by-pass pipe on the delivery line returning to the suction basin, regulated by a ball or gate valve.

Make sure that all joints are perfectly airtight: check the threads, flange and port seals, and quick couplings.

Install the pump as close as possible to the fluid to be pumped, reducing the length of the suction pipe wherever possible (maximum suction lift is 7 metres); this reduces priming time and can provide a higher flow rate.

The maximum total head of the pump is 15 metres of water column; higher hydraulic loads adversely affect pump operation and would reduce diaphragm life. For continuous use, the total pressure head must not exceed 10 metres of water column.

Correct installation of the suction and delivery pipes is ensured by observing the flow direction indicated in most versions by directional arrows on the suction and delivery ports, or in any case by checking that suction is on the port fitted with the plug or air chamber.

When installing units with internal combustion engine, make sure that the maximum engine inclination does not exceed 35° transversely or longitudinally, to ensure correct lubrication.

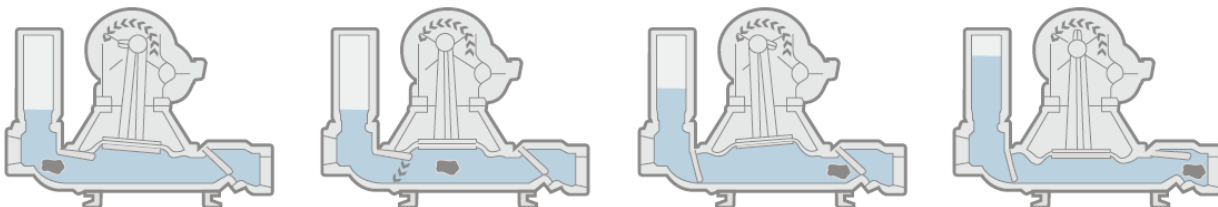

12.1 Electrical connections



Make sure that the electric pump is disconnected from the power supply before any installation or maintenance operation.

For versions with electric motor, the pump must be connected to an electrical system equipped with earthing in accordance with the local technical regulations in force. For the single-phase version, comply with the applicable technical regulations.

Make sure that the nameplate voltage matches the mains supply voltage.

Do not use the pump power cable to lift or transport it.

Installation of a high-sensitivity residual-current device is recommended as additional protection against electric shock in case of insufficient earthing.

In the three-phase version, connect the earth wire (yellow-green) of the power cable to the earth system of the power supply, making sure to install a thermal-magnetic motor protection switch or a contactor with thermal relay to protect both the motor and the pump.



It is the installer's responsibility to ensure that the power supply earthing system is installed according to the regulations.

Whenever a pump with a three-phase motor is connected to a different power line, there is an equal chance that it will rotate in either direction. Rotation in the wrong direction causes a significant reduction in flow rate and incorrect gearbox operation. The correct direction of rotation is indicated by an arrow on the gearbox body. If the motor does not rotate in the correct direction, disconnect the line power supply and swap two phases.

13. BEFORE START-UP

Read the instructions and safety rules for the motors/engines coupled to the supplied pump unit and strictly comply with the provisions issued by the motor/engine manufacturer.

For the Libellula 1-3" pump unit, before start-up the gearbox housing must be filled with oil up to the mark on the dipstick of the filler plug.

The quantity and brand of oil to use are shown in the following table.

LIBELLULA 1-3"	
Gearbox oil quantity (ISO150 viscosity)	
Die-cast aluminium version	0,65 l
Cast-iron version	0,75 l
BRAND	TYPE
Shell	Omala 150
BP	Energol GR-XP150
Castrol	Alpha SP 150
Esso	Spartan EP 150
Mobil oil	Mobilgear 600 XP150
ENI	Blasia 150

Gear lubrication takes place automatically by splash lubrication inside the gearbox housing.

14. MAINTENANCE



IMPORTANT!

All maintenance operations must be carried out with the machine stopped, disconnected from any power lines and disconnected from the suction and delivery pipes.

After the first 50 operating hours, change the gearbox oil by unscrewing the drain plug located in the lower part of the gearbox. A second oil change must be carried out after the next 500 operating hours.

Subsequent oil changes must then be carried out every 1000 operating hours or annually. For synthetic oils, follow the supplier's instructions.

Remember to regularly check the gearbox oil level using the specific minimum and maximum dipstick.

Check the diaphragm and valves every three months to assess wear.

In winter, when the machine is stopped, the pump must be protected from frost; any liquids contained inside the pump body must therefore be removed by draining them from the delivery valve after suitably tilting the pump, or through the pump body drain plug located underneath the body.

	Before each use	After each use	Every 3 months or 50 hours	Every year or 300 hours	Every 1000 hours or annually	Every 5000 hours or annually
Pump body washing		X				
Pipes and filter check	X					
Connecting rod bearing check, self-lubricated version						X
Gearbox oil level check			X			
Gearbox oil change					X	
Suction/delivery valve inspection			X			
Diaphragm inspection			X			
Nut and bolt tightening check				X		

15. SPARE PARTS

When ordering spare parts, indicate:

- a) Pump serial number.
- b) Part number and name of the required spare part.

15.1 Replacement of spare parts

Diaphragm:

Use a 19 mm wrench. Unscrew the bolts connecting the pump body to the gearbox support; then unscrew the bolts fastening the connecting rod to the diaphragm locking flange. Reassemble in reverse order.



IMPORTANT!

Warning: during this operation, support the motor/engine-gearbox part with suitable lifting equipment, bearing in mind that any pump lifting hook may not guarantee correct load balancing: therefore use appropriate means.

Suction and delivery valves:

Use a 19 mm wrench; unscrew the two fastening bolts and replace the part. A valve locating pin is positioned on the pump body to facilitate correct installation.

Flexible connecting rod:

When repairing the flexible connecting rod item 218L540I, make sure that its total length, once assembled, is 308 mm.

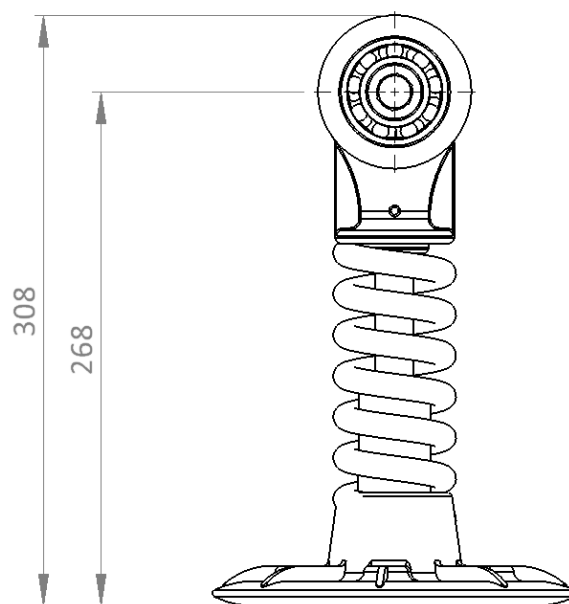

Other spare parts:

For replacement of other components, refer to the spare parts catalogue with exploded views: for special repairs it is nevertheless preferable to contact your usual supplier.

All repair operations concerning the motor/engine must be carried out in accordance with the motor/engine instruction and maintenance booklet attached to this manual.

15.2 Tightening torques

Between	and	Tightening torque		Notes
		[kgm]	[Nm]	
BODY art. 068	PORT art. 060/076	2,5	24,5	<i>Tightens the valve</i>
AL SUPPORT art. 050	AL BODY art. 068	4,5	44,1	<i>Tightens the diaphragm</i>
CAST-IRON SUPPORT item 050	CAST-IRON BODY art. 068	5,5	53,9	<i>Tightens the diaphragm</i>
CONNECTING ROD art. 218	PLATE art.220	3,5	34,3	
GEARBOX art. 207	SUPPORT art. 050	3,5	34,3	
COVER art.195	HOUSING art.204	1,6	15,7	<i>Tightens cover and gearbox housing</i>

16. MALFUNCTIONS, CAUSES AND REMEDIES

MALFUNCTION	POSSIBLE CAUSE	REMEDY
The pump runs but delivers no flow	1. Suction lift too high	1. Reduce the suction lift
	2. The suction pipe is not sealed	2. Restore sealing at all pipe joints
	3. Pump clogged	3. Remove any obstructing bodies inside the pump
	4. The suction pipe is not completely immersed in the liquid to be pumped	4. Completely immerse the suction pipe so that it does not draw in air.
	5. The suction filter is clogged	5. Clean the suction filter
	6. The suction and/or delivery valves have remained open due to the presence of a solid body	6. Remove the solid body
Low flow rate	1. Rotation speed is too low	1. Increase motor/engine rotation speed, if possible
	2. The delivery pipe is undersized or obstructed	2. Replace the pipe or clean it
	3. Too many bends or delivery pipe too long	3. Modify the delivery line
	4. Use of non-reinforced collapsible hose	4. Shorten it or fit a reinforced pipe
	5. Damaged pipes	5. Replace
Excessive noise	1. Damage to the reduction gearbox	1. Repair the gearbox through personnel authorised by the Manufacturer
	2. The pump is not properly secured to the support foot	2. Make sure the support foot is locked by the fastening pin with safety split pin inserted
	3. Suction is obstructed	3. Clean the pipes
There is water above the diaphragm	1. The diaphragm is broken	1. Replace the diaphragm
	2. The screws tightening the diaphragm are loose	2. Tighten the screws
...

For faults in the power motors/engines, see the attached instruction booklets.

17. SPECIFICATIONS

Dimensions and weight

Model	Libellula 1-3" aluminium on base	Libellula 1-3" cast iron on base
Description code	L13TAAALNVBUXE9	L13FGG3LNIBUXE9
Length x width x height	69x35x62 cm	68x35x62 cm
Net weight	36 kg	79 kg

Pump

Type	Self-priming diaphragm pump with self-lubricated flexible or rigid connecting rod
Suction port diameter	3" BSP o DN80 PN10
Delivery port diameter	3" BSP o DN80 PN10
Maximum total head	15 metri
Maximum total suction lift	7 metri
Maximum flow rate	300 l/min (20 m ³ /h)
Priming time	20 s
Maximum passage of solids	50 mm
Maximum pressure	1,5 bar

Gearbox

Reduction ratio	1:43@2800rpm	1:38@1400rpm	1:30@1400rpm
No. of pump pulsations (50 Hz)	65/min	37/min	47/min

A spare parts catalogue is attached to the use and maintenance manual (see also the QR code below).

Aluminium version



Cast-iron version



18. DISPOSAL

In the event of demolition or decommissioning of the machine, separate its parts according to the manufacturing materials and dispose of them in compliance with the regulations in force in the country where demolition or decommissioning takes place.

PROFESSIONAL EEE - INFORMATION FOR USERS



Pursuant to art. 26 of Legislative Decree no. 49 of 14 March 2014, "Implementation of Directive 2012/19/EU on waste electrical and electronic equipment"

The crossed-out wheeled bin symbol shown on the equipment or its packaging indicates that the product must be collected separately from other waste at the end of its useful life.

Separate collection of this equipment at end of life is organised and managed by the producer. Users wishing to dispose of this equipment may therefore contact the producer and follow the system adopted by the producer to allow separate collection of end-of-life equipment, or independently select an authorised management chain.

Proper separate collection for subsequent sending of the decommissioned equipment for recycling, treatment and environmentally compatible disposal helps to avoid possible negative effects on the environment and health and promotes reuse and/or recycling of the materials of which the equipment is composed.

Unauthorised disposal of the product by the user entails application of the penalties provided for in Legislative Decree 152/2006.

Caffini Cipriano s.r.l.

Via G. di Vittorio, 46 – 43044

Lemignano di Collecchio (Parma) – Italy

phone +39 0521 804325 **web** www.caffinipumps.it

e-mail info@caffinipumps.it



Caffini PUMPS

